



**First in Quality. Built to Last.**

# VCTS

## VERTICAL CASE TRANSPORT SYSTEM

### OUR INNOVATIONS MEET YOUR NEEDS

Eastey's Vertical Case Transport System allows users to print on two sides of a case eliminating the need for pre-printed cases or expensive labeling equipment and supplies. Adjustable width settings on our standard VCTS allow users to print on cases ranging in size from 10" x 10" up to 33" x 40". VCTS-XL allows cases ranging in size from 10" x 10" up to 48" x 40".

### AUTOMATIC OPERATION

Designed for off-line case printing, the VCTS automatically feeds blank cases through a print station that is ideal for mounting hi-resolution inkjet printers and offers the ability to print virtually anywhere on either side of the case. Open access to printheads allows for easy maintenance and quick adjustments. The VCTS also features an input hopper that can hold up to 90 flat single wall cases and can easily be reloaded by one person.

### EASY TO PROGRAM

The VCTS includes a programmable counter that keeps track of batch quantities, rate of operation, and elapsed run time, allowing users the ability to customize case runs. The system can be easily programmed to shut down when the maximum count is reached. The VCTS batch counter is the ideal solution for users looking to print a message on specific number of cases while eliminating the need for manual case counting.

**EASTEY**  
First in Quality. Built to Last.

## CUSTOM CASE PRINTING MADE EASY

The VCTS is designed for off-line custom case printing and eliminates the need for pre-printed cases or expensive labeling equipment.

### INDUSTRIAL STRENGTH OPERATION

A single drive motor and an aggressive industrial strength drive belt make the VCTS a workhorse that will stand up to your toughest challenges. Each VCTS is made from powder coated 12 gauge steel that will withstand even the most rugged applications.

### INCREASED INVENTORY SPACE

Eastey's VCTS is an ideal option for users who are looking to increase storage space by eliminating pre-printed case inventories. Equipped with casters, the VCTS can be easily moved throughout the plant to accommodate your various printing needs.

### AFFORDABLE VERSATILITY

If you've wanted to begin printing your cases or expand your operation's versatility, but felt your budget restricted you from doing so, Eastey's VCTS offers a new level of economy. Eliminate the high costs associated with pre-printed cases by printing specific product information directly onto blank cases. Any way you look at it, Eastey's VCTS provides users with an affordable solution to meet your case printing needs.

### THE RIGHT SOLUTION

Rugged design. Proven reliability. Simple operation. Your benefits go on and on. When it comes to industrial operation, rely on Eastey to provide the right solution for your case transport needs.

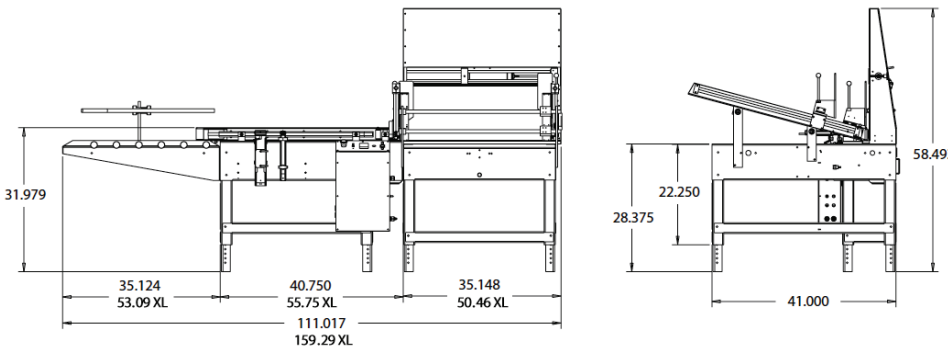
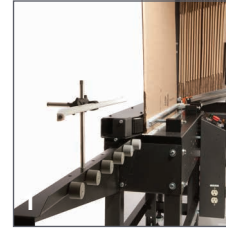

1. Industrial strength drive belts move boxes consistently at 72 feet/minute.
2. Simple and rugged control interface for easy operation.
3. Easy to load input hopper holds up to 90 flat single wall cases and can be loaded by one person.
4. Designed for use with Industrial Ink Jet Printers. Allows printing on all four panels of the case. (Shown with Squid Ink PZ Pilot Pro printer.)

**VCTS FEATURES**

- Plug-in and go operation
- Fast and easy box size changes
- Powder coated 12 gauge steel
- Low maintenance
- Industrial strength side belts
- Accommodates wide box size change
- Adjustable leg extensions
- Simple integration with ink jet printers
- Heavy duty locking casters

**VCTS TAPING SPECIFICATIONS**

Machinery Makeup	Industrial strength 12 gauge steel, powder coated for durability
Belt Speed	72 feet/minute (approx. 50 - 10" x 10" cases/min)
Input Hopper	Capacity of up to 90 flat single wall cases
Input Hopper Adjustments	Standard Model VCTS 10" to 33" width, VCTS-XL 10" to 48" width

BOX SPECIFICATIONS (Flat Dimensions)	Width
Minimum Box Size	10.0" (Standard Model & VCTS-XL)
Maximum Box Size	33.0" (Standard Model) 48" (VCTS-XL)
Programmable Counter	Designed for batch operations, rate metering, and elapsed counting
Printing System Compatibility	Designed for ink jet printing system compatibility
Casters	Attached to each section for transport throughout the plant
Electrical Requirements	110 VAC, 60Hz, 4.0A
Air Requirements	80 PSI, 1/4" NPT Fitting

**VCTS OPTIONAL ACCESSORIES**

Ink Jet Printing System	Hi-resolution printing system capable of printing bar codes, graphics and text
-------------------------	--



7041 Boone Avenue North, Brooklyn Park, MN 55428  
(763) 428-4846 1 (800) 835-9344  
www.eastey.com info@eastey.com

