

 **First in Quality. Built to Last.**



AUTOMATIC BUNDLER PROFESSIONAL SERIES

RELIABLE AUTOMATIC BUNDLING

EASTEY'S automatic bundlers offer the reliability needed to provide a "bull's-eye closure" on trays, individual, or multi-packed products.

MODEL

EB25A

BUILT RIGHT...PRICED RIGHT

Proven reliable over and over again, this EASTEY automatic bundler provides you with all the quality features found in much higher priced machines. EB25A is designed and built to give you all the features needed for positive sealing a wide variety of films including polyolefin, polyethylene, and PVC.

RUGGED DESIGN

EASTEY'S automatic bundlers are expertly welded on ¼" cold rolled steel frames and designed to handle the day to day abuse of most bundling applications. Each bundler utilizes two rolls of single wound film mounted on the same side of the machine and upper and lower power film unwind for ease of use. See for yourself why EASTEY has been a leader in the shrink packaging industry for over 25 years.

STANDARD FEATURES

- Designed to seal most polyolefin, polyethylene, and PVC shrink films
- 25" wide hot knife seal provides a consistent "bull's-eye" closure
- Upper and lower powered film unwind for smooth feed of film
- All-welded main frame from ¼" cold rolled steel for durability
- 12" product pass through height accommodates 11" tall product
- Bases supplied with casters for easy transport
- Reliable product transfer between infeed and exit conveyor
- Soft start infeed and outfeed conveyors to reduce product shifting
- Fixed lower seal bar provides a clean consistent seal and accommodates random height products
- Automatic seal system with pneumatic hold for consistent pressure
- Self tracking conveyor belt and product indexing
- 34.75" conveyor height
- Siemens PLC touchscreen with full color HMI
- Flexibility for fully automatic or single product operation
- Small footprint – 61.5"L x 41.8"W x 71.3"H
- Durable custom two-part epoxy finish resists scratching
- 25" max film width
- 14" max film OD
- 220V standard; optional 480V
- Requires 60 psi; 3.5 cfm
- Easy to use design requires minimal training and maintenance
- Made in the USA

EASTEY
First in Quality. Built to Last.

Automated Marking, Labeling & Packaging Systems
8785 Ag Park Drive North
Batavia, NY 14020
Tel: 1-800-627-5832 | Fax: 585-344-4109
www.marktecprods.com



1. **Color Touchscreen Panel**
Color PLC touchscreen features simple menus for easy operation, and can be password protected if needed
2. **Conveyor Infeed and Outfeed**
Soft start infeed and outfeed conveyors reduce product shifting
3. **25" Wide Seal Bar**
Fixed lower seal bar provides a clean consistent seal and accommodates random height products
4. **Hot Knife Seal System**
Hot knife seal bar provides positive sealing on a wide variety of films

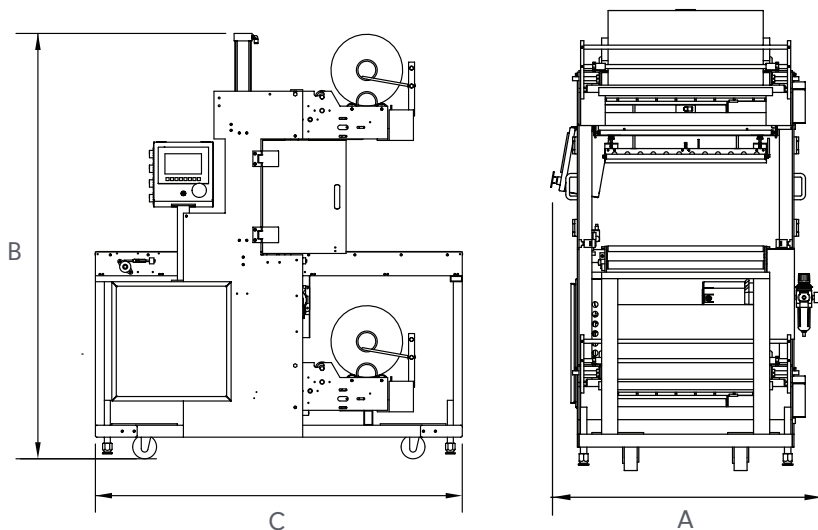

MODEL NUMBER	MACHINE DIMENSIONS			SEAL DIMENSIONS		CONVEYOR HEIGHT		STANDARD POWER			WEIGHT	SHP WT.
	WIDTH (A)	HEIGHT (B)	LENGTH (C)	WIDTH	HEIGHT	MIN	MAX	VOLTS	AMPS	PHASE		
EB25A	41.8" 106 cm	71.3" 181 cm	61.5" 156 cm	25" 64 cm	12" 30 cm	34.75" 88 cm	38" 97 cm	220	10	1	1400	1600



7041 Boone Avenue North, Brooklyn Park, MN 55428
 (763) 428-4846 1 (800) 835-9344
 www.eastey.com info@eastey.com

