

 **First in Quality. Built to Last.**



VCTS

VERTICAL CASE TRANSPORT SYSTEM

OUR INNOVATIONS MEET YOUR NEEDS

Eastey's Vertical Case Transport System allows users to print on two or four adjacent sides of a case eliminating the need for pre-printed cases or expensive labeling equipment and supplies. Adjustable width settings on our standard VCTS allow users to print on cases ranging in size from 10" x 10" up to 33" x 29". A larger VCTS -XL allows cases from 21" x 10" up to 48" x 29".

AUTOMATIC OPERATION

Designed for off-line case printing, the VCTS automatically feeds blank cases through a print station that is ideal for mounting hi-resolution inkjet printers and offers the ability to print virtually anywhere on either side of the case. Open access to printheads allows for easy maintenance and quick adjustments. The VCTS features an input hopper that has a capacity of up to 75 flat single wall RSC; up to 3/4 magazine capacity and can easily be reloaded by one person.

EASY TO PROGRAM

The VCTS includes a programmable counter that keeps track of batch quantities, rate of operation, and elapsed run time, allowing users the ability to customize case runs. The system can be easily programmed to shut down when the maximum count is reached. The VCTS batch counter is the ideal solution for users looking to print a message on specific number of cases while eliminating the need for.

CUSTOM CASE PRINTING MADE EASY

The VCTS is designed for off-line custom case printing and eliminates the need for pre-printed cases or expensive labeling equipment.

CONVENIENT CASE COLLECTION

Eastey's exit hopper collection bin is a convenient way to collect cases fed through the VCTS. The exit hopper is adjustable to accommodate the available box sizes in both the VCTS standard and VCTS-XL models. The collection bin conveniently collects up to 75 flat single wall RSCs and keeps them stored upright until they can be transported to another area. Vertical Case Transport Systems can be ordered with an exit hopper, one can be added at a later day, or a collection bin can be ordered as an option and integrated with previous VCTS systems.

INCREASED INVENTORY SPACE

Eastey's VCTS is an ideal option for users who are looking to increase storage space by eliminating pre-printed case inventories. Equipped with casters, the VCTS can be easily moved throughout the plant to accommodate your various printing needs.

AFFORDABLE VERSATILITY

Eliminate the high costs associated with pre-printed cases by printing product specific information directly onto blank cases. Any way you look at it, Eastey's VCTS provides users with an affordable solution to meet your case printing needs.

THE RIGHT SOLUTION

Rugged design. Proven reliability. Simple operation. Your benefits go on and on. When it comes to industrial operation, rely on Eastey to provide the right solution for your case transport needs.



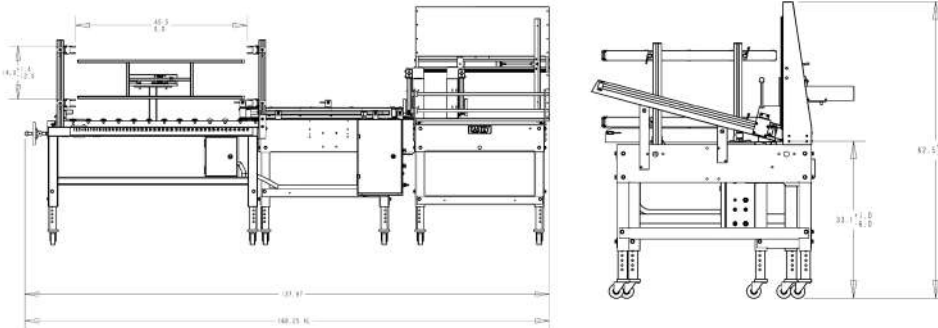
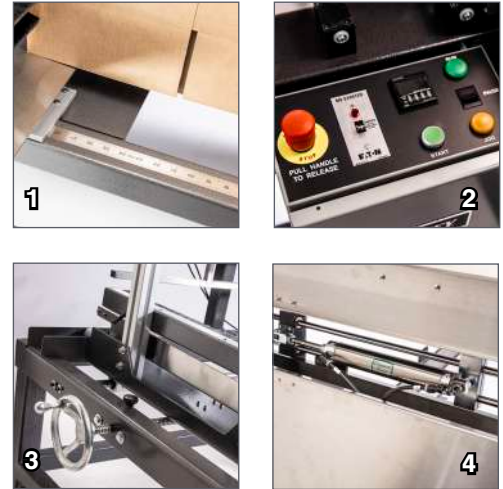

1. Adjustable collector bin with ruler to easily switch between different width cases.
2. Simple and rugged control interface for easy operation.
3. Hand crank wheel easily adjusts width of collector bin.
4. Pneumatic pusher arm can be adjusted for different width cases.

VCTS FEATURES	VCTS SPECIFICATIONS			
<ul style="list-style-type: none"> Plug-in and go operation Fast and easy box size changes Low maintenance and easy to use Powder coated 12 gauge steel Industrial strength side belts Accommodates wide range of box sizes Easy to load input hopper Optional exit hopper for easy case collection Adjustable leg extensions Heavy duty locking casters Simple integration with ink jet printers 	Machinery Makeup	Industrial strength 12 gauge steel, powder coated for durability		
	Belt Speed	72 feet/per minute (approx. 40 - 10" x 10" cases/min); throughput determined by box length		
	Input Hopper	Capacity of up to 75 flat single wall RSC; up to 3/4 magazine capacity		
	Input Hopper Adjustments	Standard Model VCTS 21" to 33" width, VCTS-XL 21" to 48" width		
	BOX SPECIFICATIONS (Flat Dimensions)	Width	Height	
	Minimum Box Size	10.0" (Standard Model & VCTS-XL)	10.0"	
	Maximum Box Size	33.0" (Standard Model) 48" (VCTS-XL)	29.0"	
	Programmable Counter	Designed for batch operations, rate metering, and elapsed counting		
	Printing System Compatibility	Designed for ink jet printing system compatibility		
	Casters	Attached to each section for transport throughout the plant		
Electrical Requirements	110 VAC, 60Hz, 4.0A			
Box Requirements	Single wall RSC only, minimum C flute; no trays or cartons; no square cases (ie. 10 x 10, 14 x 14, etc.)			
Air Requirements	80 PSI, 1/4" NPT Fitting			

VCTS OPTIONAL ACCESSORIES	
Ink Jet Printing System	Hi-resolution printing system capable of printing bar codes, graphics and text
Exit Hopper	Added to existing Vertical Case Transport Systems for easy case collection

©2023 Easteey. Specifications subject to change. All trademarks are property of their registered owners.



7041 Boone Avenue North
Brooklyn Park, MN 55428
(763) 428-4846 www.easteey.com
1 (800) 835-9344 info@easteey.com

MARKTEC
Automated Marking, Labeling & Packaging Systems
8785 AgPark Drive N.
Batavia, NY 14020
Tel: (585) 344-4102 | 1-800-627-5832
www.MarktecProds.com
Sales@MarktecProds.com

