

Limitag V5 Lite

Omnidirectional printing

Modular design

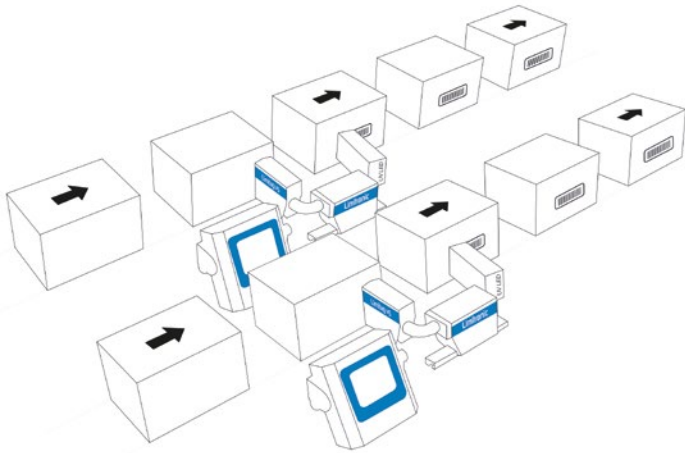

ADVANTAGES

- Personalization. Short runs. Promotions
- Stock reduction of pre-printed boxes
- Practically zero maintenance
- No interruptions when adding consumables
- Print on inclined conveyor belts

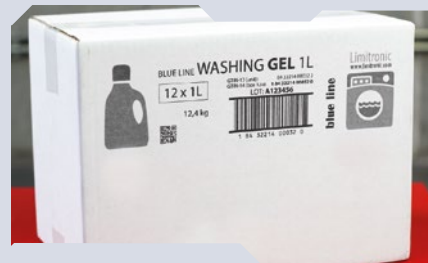

CHARACTERISTICS

- Native 180dpi resolution
- Multiple densities and contrasts
- High quality barcodes. GS-1 Standard
- Intuitive user environment
- On screen preview of printing layout (WYSIWYG)
- Oil based and UV LED ink
- Integrated WebServer
- External message selection through hardware
- Post-print barcode scanner integration
- Scripting for total job personalisation



Graphic Solid Inks, Inc.
6845 Shiloh Rd E
Alpharetta, GA 30005
Ph: 678.264.4008
Email: info@gsinks.com
gsinks.com

SPECIFICATIONS

DE IMPRESIÓN PRINT

Printer head resolution: 180 dpi

Print speed:

30 m/min @ 180dpi
0.2 - 96 m/min according to the resolution

Height: 72 mm

Maximum length: 1100 mm

Densities: 3 levels

Fonts: True Type™, Open Type™ fonts

Character coding: Unicode

Barcodes: GS-1 Standard
EAN/UPC, ITF-14, GS1-128, GS1 Datamatrix, GS1 QR Code

Printing in various fields:

User (personalised fields) and automatic based fields (expiration dates, shift codes, counters)

Orientation:

Vertical (side of product)
Horizontal (cover of product)
Inclined printing (any angle)

ELECTRICAL

Power supply:

Auto-range
88-264VAC / 47-63 Hz, 108 W (max)

Input:

2 x printer signals
1 x encoder
5 x programmable electronics
(external message selection)

Output (through colour):

2 x programmable electronics
2 x status indicators

Communication ports:

1 x RS-232
1 x Ethernet 10/100
1 x USB
1 x Wi-Fi (Optional)

ENVIRONMENTS

Working environment:

5 - 45 °C (41 - 113°F)

Protection:

IP 50 (controller)

USER INTERFACE

Touch screen, colour, 7" Message selection with preview WYSIWYG
Diagnostics

COMUNICACIONES

Individual communications protocol
WebServer
Windows™ Driver
Connectivity with external database and ERP
Remote assistance
Datamax (DPL), Zebra (ZPL2) protocol emulation option

OTHERS

Weight: 6kg

Ink:

Oil based ink
UV LED ink

Colors:

Black
Black (high contrast) Cyan
Magenta
Yellow
Others (consult)



PRINTABLE PRODUCTS

Cardboard, glossy paper, art paper, paper, fabrics, wood, plastic, metal, nylon, EPS, and more.

OPTIONS

Encoder, post-printing barcode verification, alarm beacon, barcode scanner for product selection

Limitag v5 Lite

UV LED

UV LED



Printing immediately sets
Useful, long life span with low maintenance
Energy efficient

FEATURES

Several heights available
Instant on/off
Safety through double activation input
Adjustable intensity

DIMENSIONS

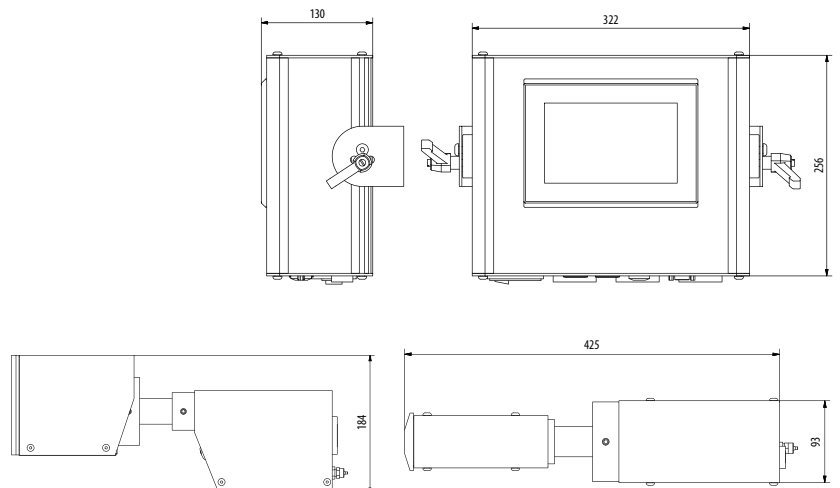

Graphic Solid Inks, Inc.
6845 Shiloh Rd E
Alpharetta, GA 30005
Ph: 678.264.4008
Email: info@gsinks.com
gsinks.com