



**Shrink Sleeve Solutions**  
To Make Your Product **Stand Out**



# AUTO BANDIT

## Automatic Tamper-Evident Banding Machine

The AutoBandit automatic tamper-evident band applicator from American Film & Machinery is designed to apply tamper bands to round, rectangle, oval, or unique containers up to 9.85" in diameter. The AutoBandit is a fully functioned applicator and shrink tunnel that applies the band and shrinks it in one pass. The applicator and tunnel are combined in one machine with a small footprint to easily fit in most production environments.

AutoBandit replaces hand applied preforms with the automatic application of tamper-evident bands. The system features three zones: sealing, preheat, and shrink. First, the shrink band wraps around the leading edge of the product, is then sealed, cut, and preheated to hold the band in place prior to a final shrink inside the tunnel. Popular applications for this machine include dairy, bakery, pre-made food and deli trays, candy, nuts, pharmaceutical, nutraceutical, toys/games, and more.

- Reduced Labor Cost - eliminates the need to hand apply preformed bands
- Reduced Material Cost - one roll of film can replace a variety of preform band sizes and also lower costs to inventory and store multiple preform sizes
- Eliminates Custom Tooling - for unique or custom sized preform bands
- Consistent Appearance and Seal - machine applied for a consistent appearance
- Ease of Application - easy to use design requires minimal training, maintenance, and provides trouble-free operation

- Unique Container Shapes - applies tamper-evident bands to round, rectangle, oval, or unique containers

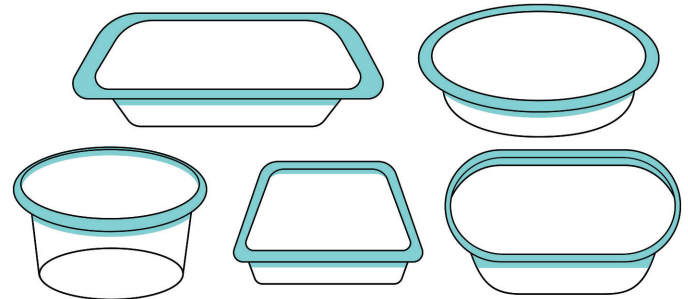

### STANDARD FEATURES

- Uses single wound rolls of film
- Designed to shrink most PET, PLA, or PVC shrink films
- Wide range of product sizes between 3.15" - 9.85" in diameter, and up to 5.9" in height
- Quick and easy changeovers do not require tools and can be completed in minutes
- Intuitive user interface with notepad function to keep track of multiple product setup recipes
- High velocity blower motors circulate air volume inside tunnel
- Small footprint easily fits in most production environments
- Heavy duty casters and leveling pads for transportation within plant
- Easy to use design requires minimal training, maintenance, and offers trouble-free operation
- CE Certification

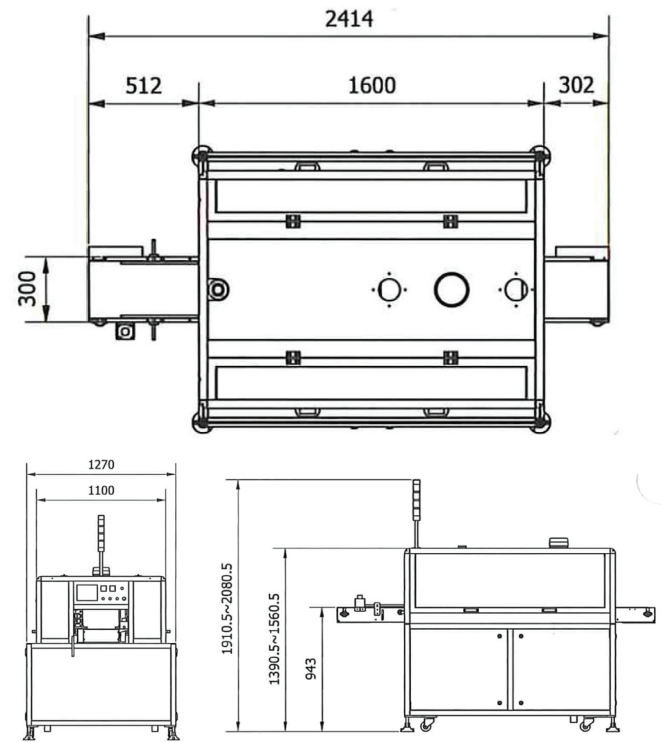

TECHNICAL SPECIFICATIONS	AUTO BANDIT
Machine Zones	Seal, preheat, shrink
Product Speed	Up to 30 CPM
Film Thickness	.025mm - .07mm (25 - 70 microns)
Film Width	1.5" - 5.9" (38mm - 150mm)
Package Width	3.15" - 9.85" (80mm - 250mm)
Package Height	1.2" - 5.9" (30mm - 150mm)
Minimum Package Weight	5.3 ounces (150g)
Overall Machine Dimensions	95.0" (2414mm) L x 50.0" (1270mm) W x 61.4" (1560mm) H
Tunnel Opening	9.8" (250mm) W x 5.9" (150mm) H
Conveyor Belt Width	11.8" (300mm)
Power	220V, 3 Phase, 50/60 Hz
Air Requirements	80 PSI, 1/4" NPT fitting

©2024 American Film & Machinery. Specifications subject to change. All trademarks are the property of their respective owners. Product samples shown illustrate the capabilities of AFM and do not necessarily represent a business relationship between the companies.



**Automated Marking, Labeling & Packaging Systems**

**8785 AgPark Drive N.  
Batavia, NY 14020**

**Tel: (585) 344-4102 | 1-800-627-5832**

**www.MarktecProds.com  
Sales@MarktecProds.com**



- 1. Operator Controls**  
*Easy to use control panel allows users to adjust for their specific application*
- 2. Seal Head Entrance**  
*The shrink band wraps around the leading edge of the product, is then sealed, cut, and preheated to hold the band in place prior to a final shrink inside the tunnel*
- 3. Exit from Tunnel**  
*High quality electric shrink tunnel provides uniform heat distribution and a high quality finish*
- 4. Finished Product**  
*Positive shrinking on most PVC, PET, and OPS films provides a tamper evident seal and product protection*



7041 Boone Avenue North, Brooklyn Park, MN 55428  
(714) 974-9006 www.afmsleeves.com  
info@afmsleeves.com

